

MKMFH01 & MKMFH02 Hydra 2 Mountain Freehub XD & HG

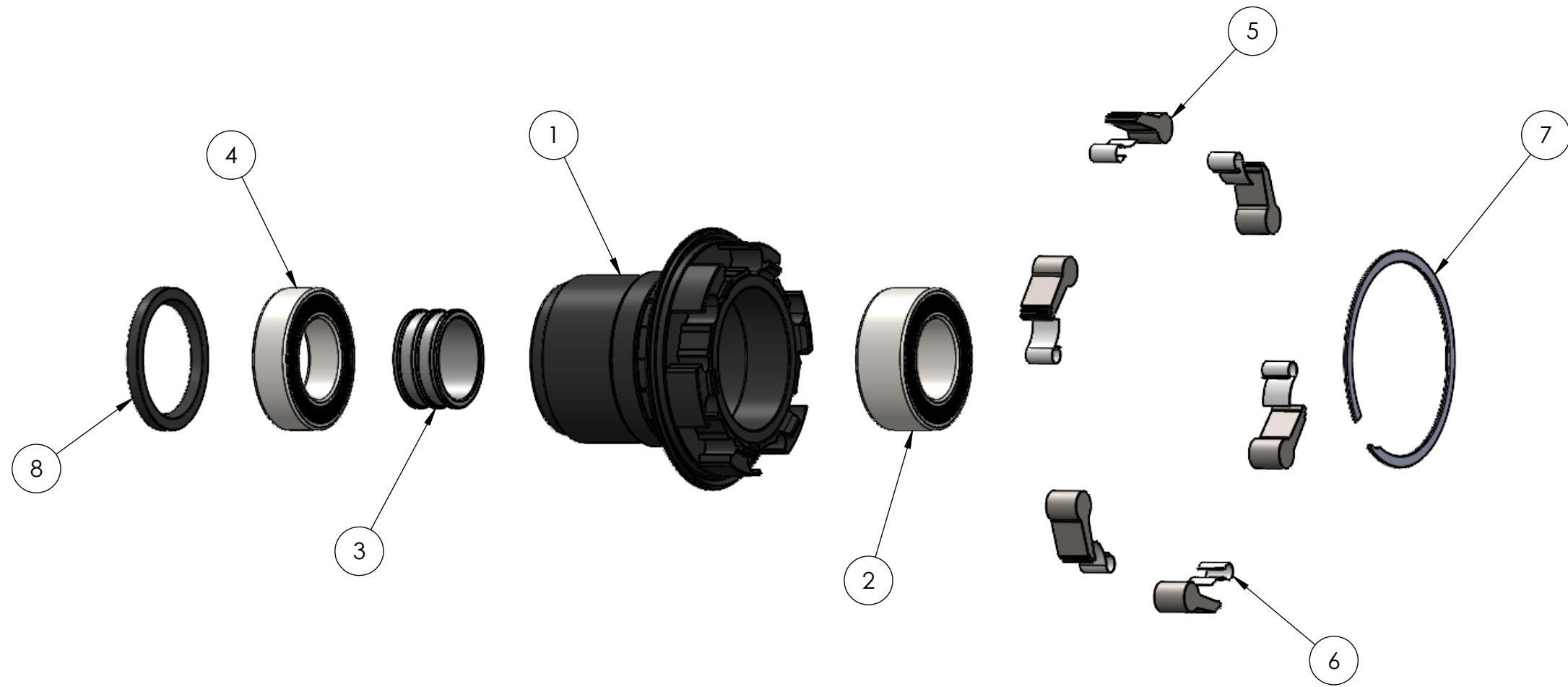

ITEM NO.	PART NUMBER	DESCRIPTION	QTY.
1	MKMFH02	Hydra 2 Freehub XD	1
2	BB152610	Ball Bearing 15 x 26 x 10 DR	1
3	RFH3516	Solix MTN FHB Spacer	1
4	BB15267A5	Ball Bearing 15 x 26 x 7	1
5	MFH4532	Hydra 2 Pawl	6
6	HFH2533	Hydra - 1/1 - Solix Pawl Spring	6
7	OEFH1131	Smalley Retaining Ring	1
8	OEAX1640	26mm Radial Lip End Cap Seal	1

PROPRIETARY AND CONFIDENTIAL
THE INFORMATION CONTAINED IN THIS DRAWING IS THE SOLE PROPERTY OF INDUSTRY NINE COMPONENTRY. ANY REPRODUCTION IN PART OR AS A WHOLE WITHOUT THE WRITTEN PERMISSION OF INDUSTRY NINE COMPONENTRY IS PROHIBITED.

UNLESS OTHERWISE SPECIFIED:		NAME	DATE
DIMENSIONS ARE IN INCHES TOLERANCES: FRACTIONAL: ± 1/32 ANGULAR: ± 0.5 deg TWO PLACE DECIMAL ±0.01 THREE PLACE DECIMAL ±0.005		DRAWN	
INTERPRET GEOMETRIC TOLERANCING PER:		CHECKED	
MATERIAL		ENG APPR.	
FINISH		MFG APPR.	
NEXT ASSY	USED ON	Q.A.	
APPLICATION		COMMENTS:	
		DO NOT SCALE DRAWING	

Freehub Spec	
P/N	Desc.
MFH4515	MTN XD
MFH4513	MTN HG

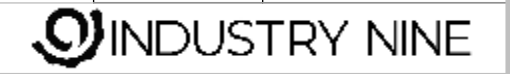

TITLE:		
SIZE	DWG. NO.	REV
B		
SCALE: 1:2	WEIGHT:	SHEET 1 OF 1