

EC HEADTUBE

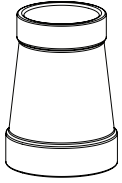

Industry Nine products are designed to keep you in the saddle and out of the service queue. Regular service and maintenance is simple and can be performed with basic tools readily available to the home or shop mechanic - *no proprietary tools are required.* To properly service your Industry Nine iRiX Headset, please follow the steps below.

For more information: Call 828-210-5113, email service@industry9.com or visit industry9.com/support

TOP COVER ASSEMBLY

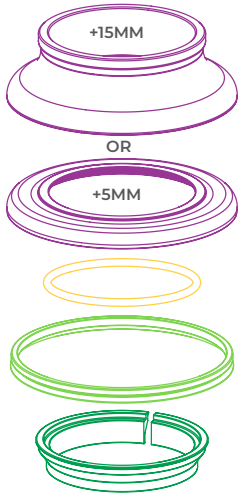

CUPS

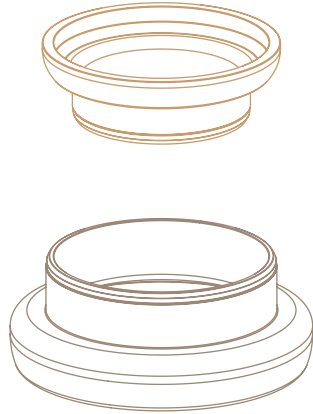

SHIMS



BOLT | TOP CAP | STAR NUT

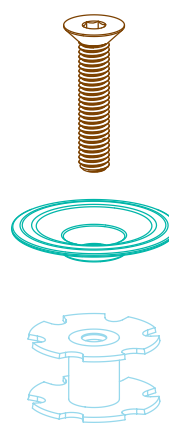

BEARINGS | SEAL | CROWN RACE

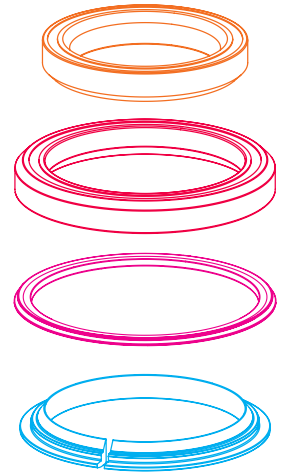

1

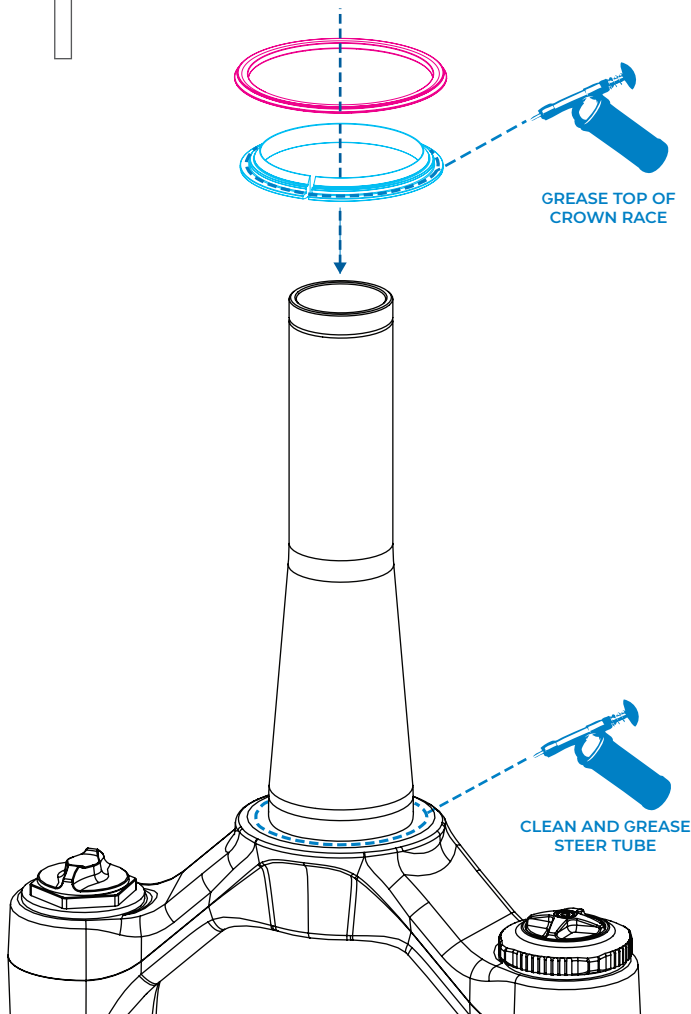

2

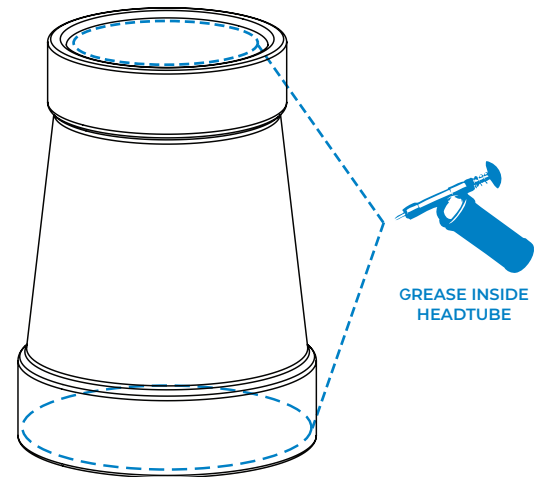

3

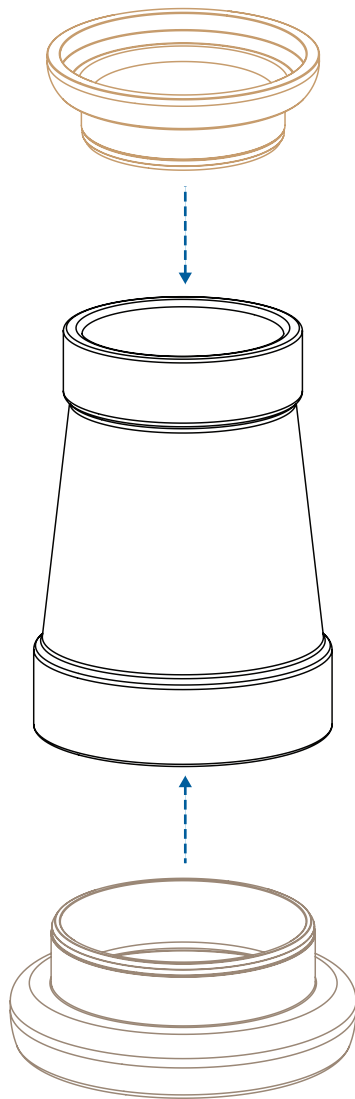
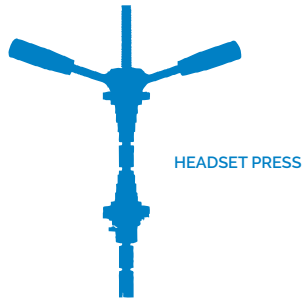

4

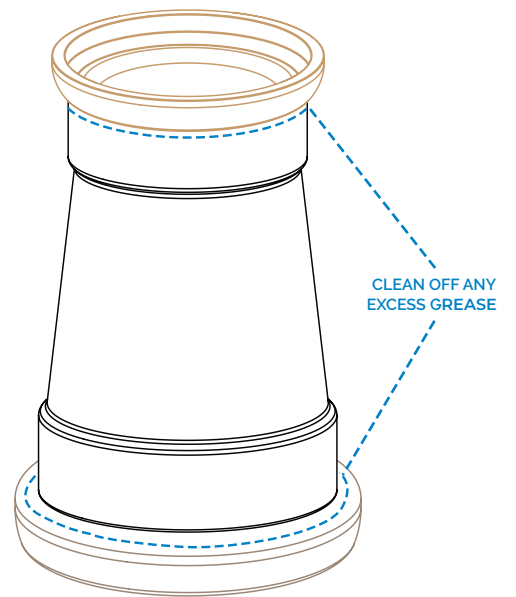

4

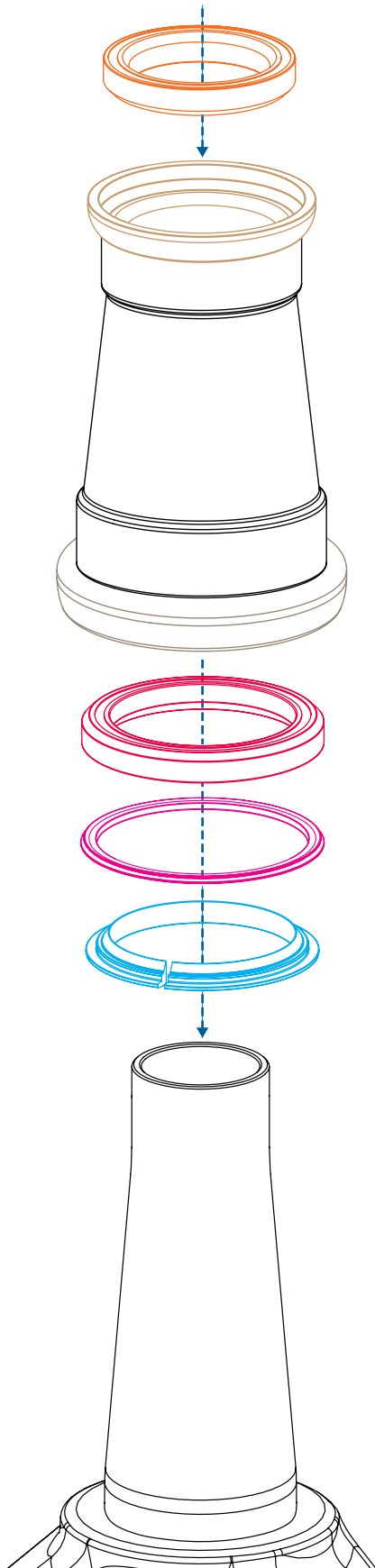

5

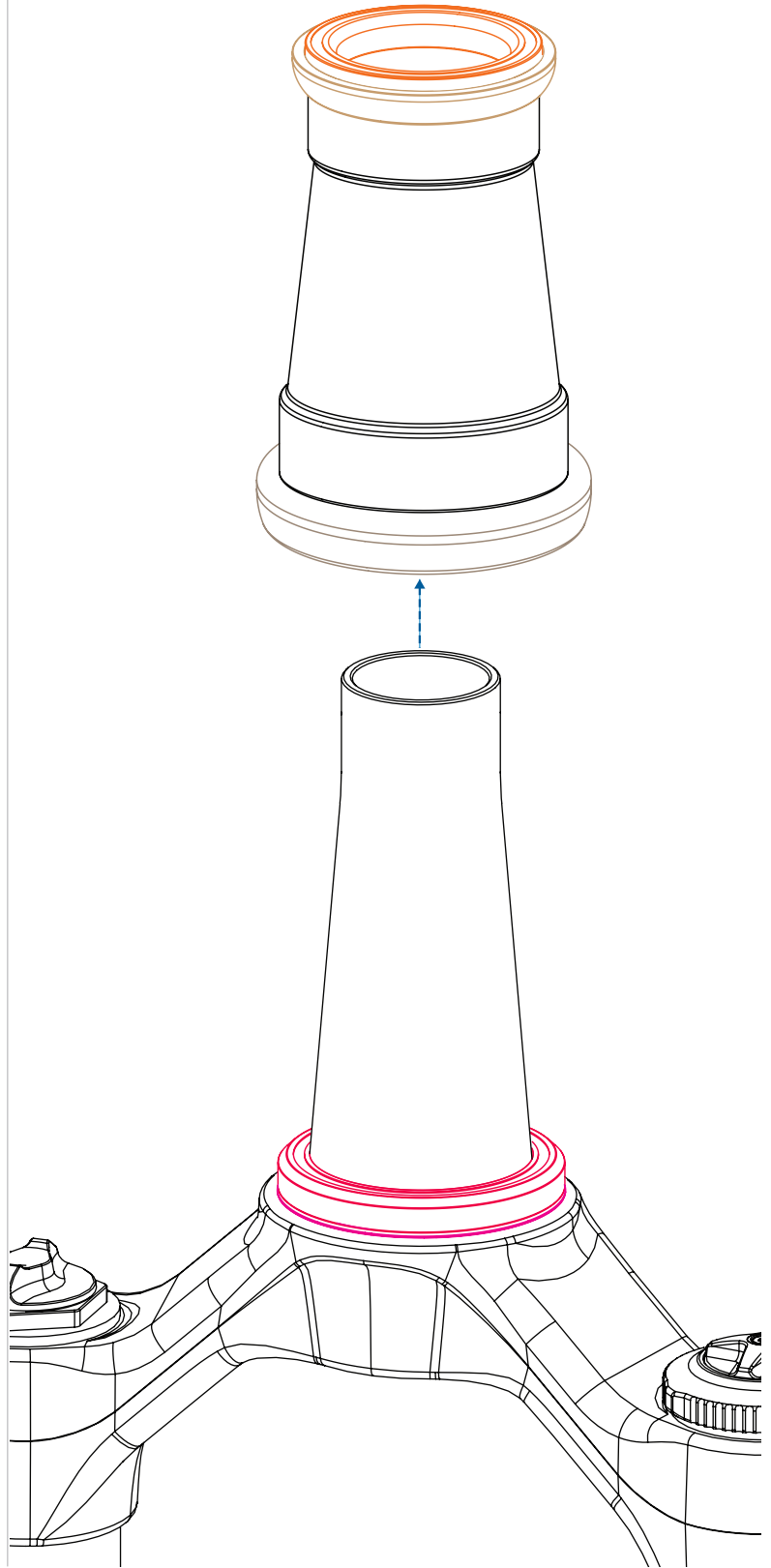

6

+5mm

+15mm

OR

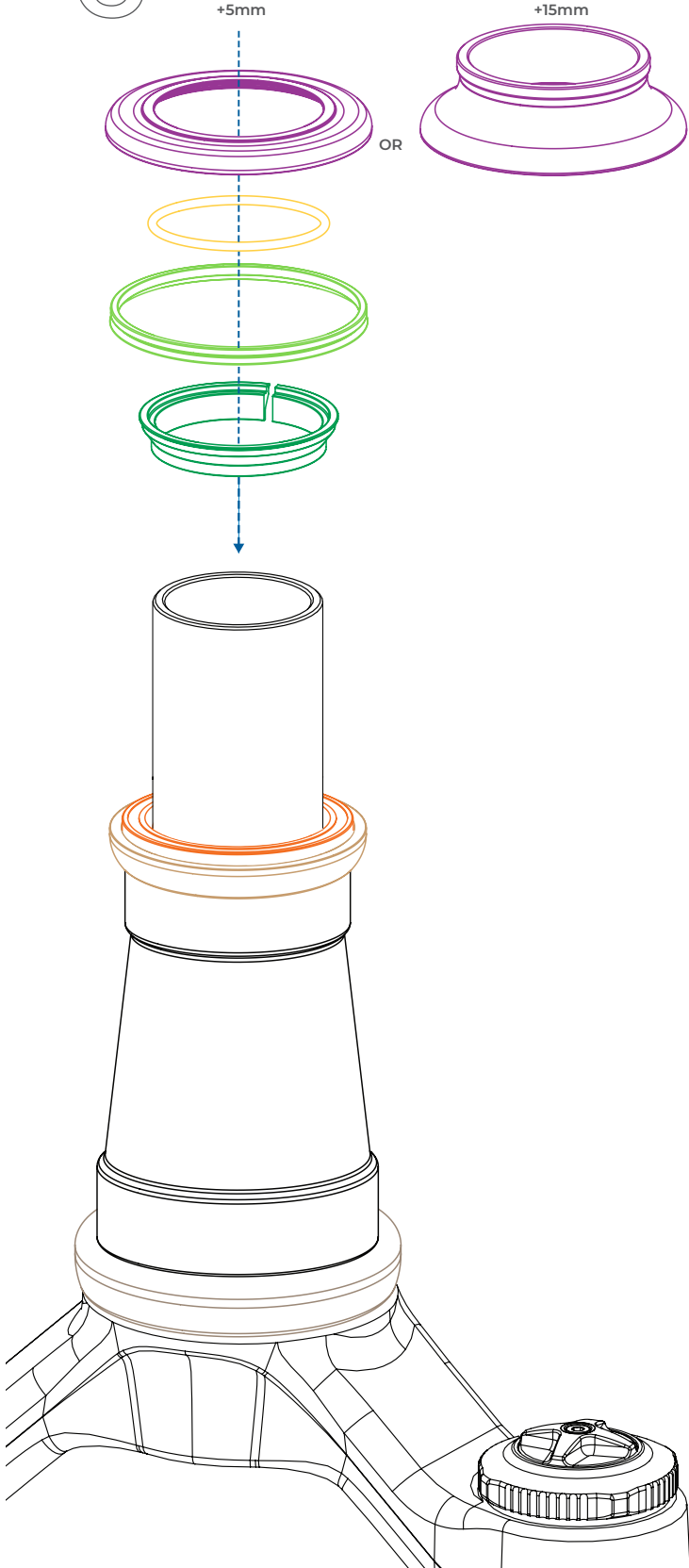

7

+15mm

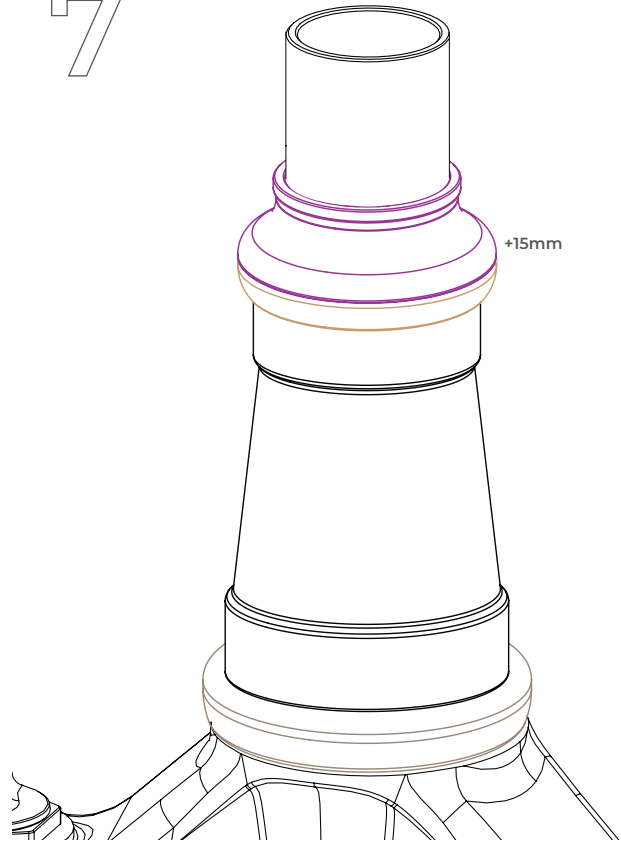

+5mm

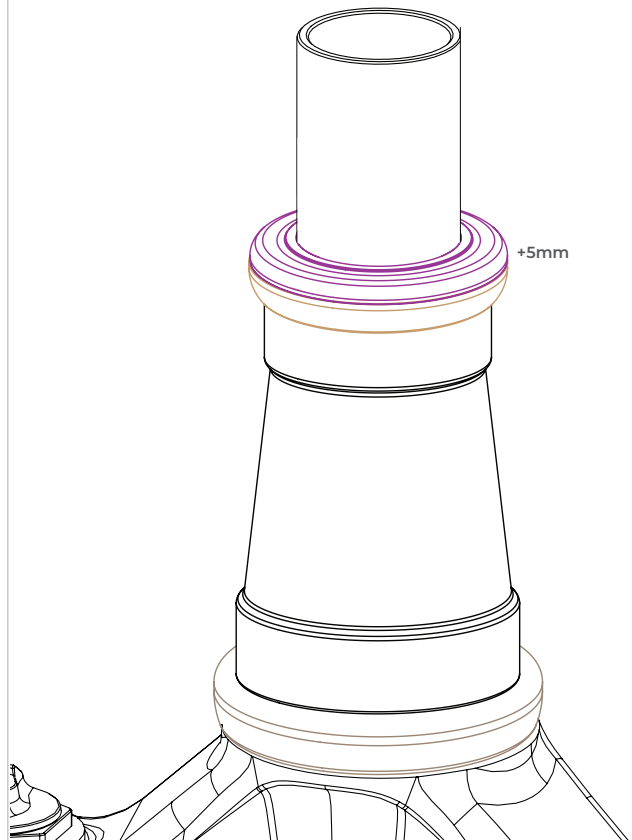

INDUSTRY NINE **RiX** INSTALL GUIDE
EC Headset

8

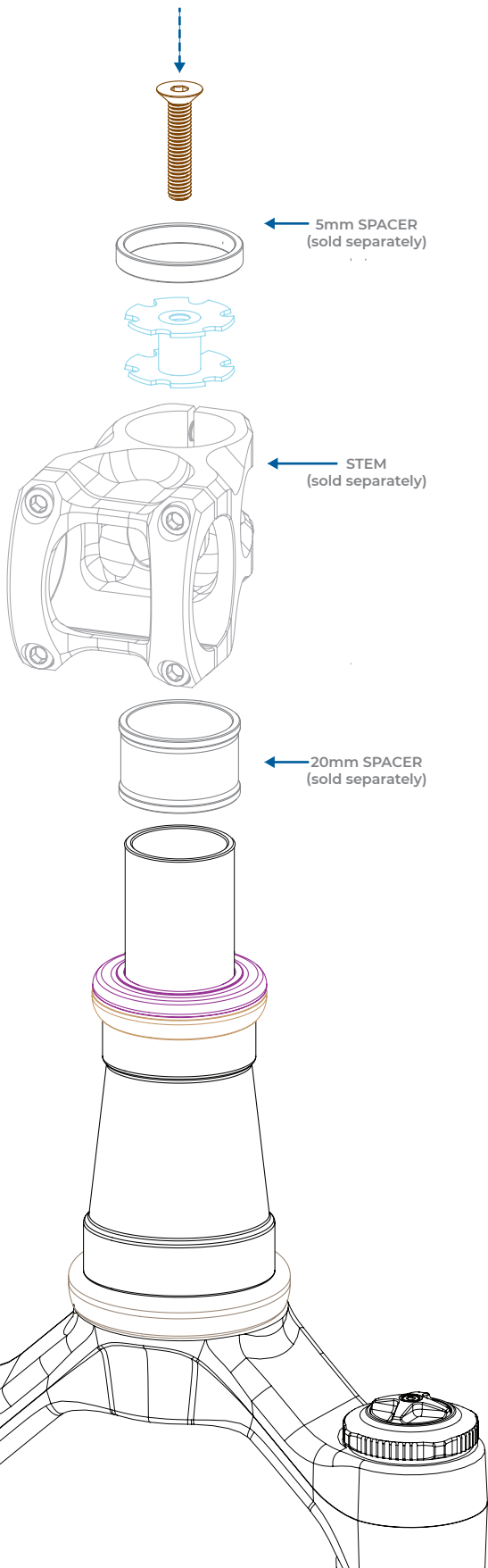

9

